



Multi-Position Air Handler

Constant Torque

AMC24S1A

Parts List



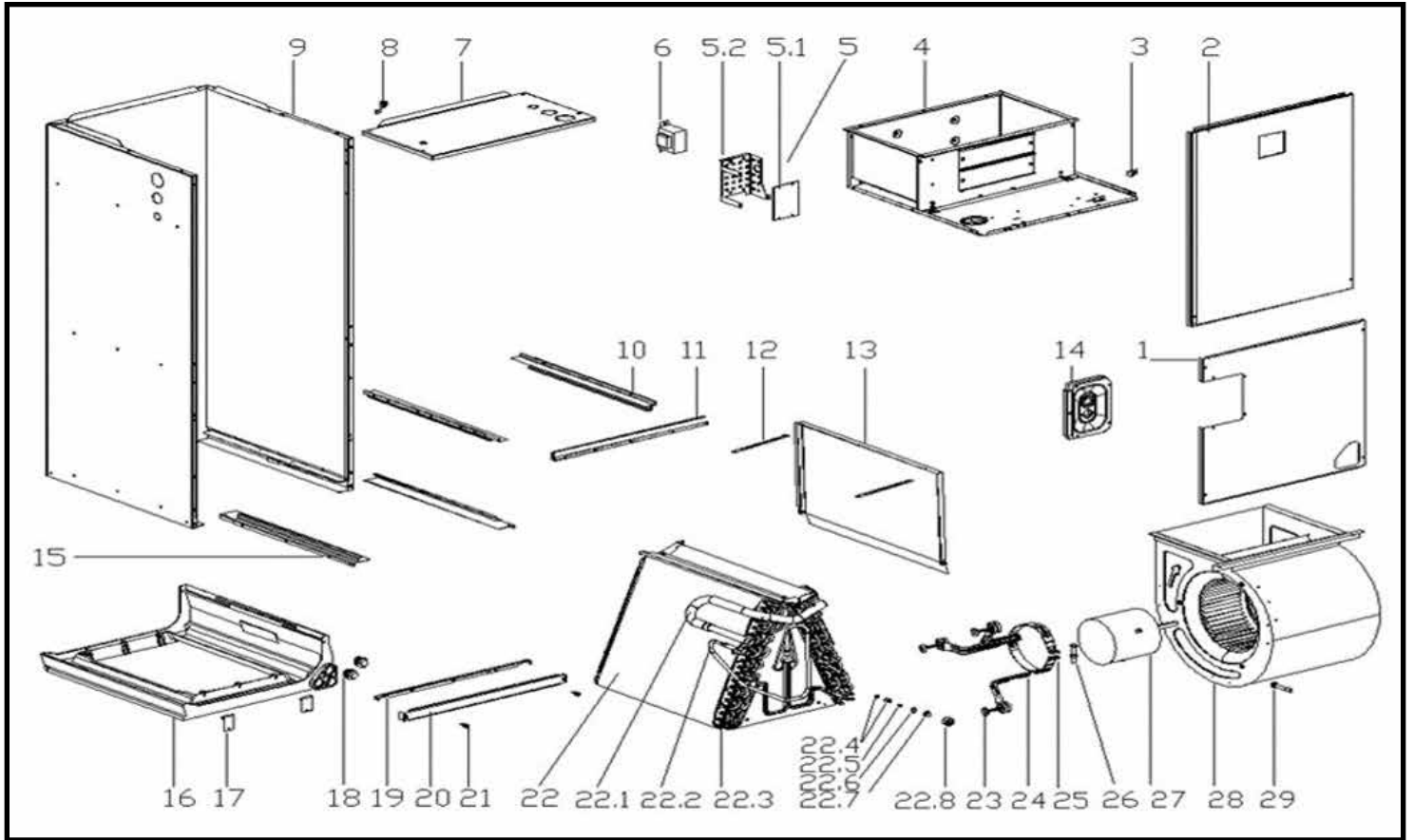

EX_ID	Spare Parts Code	Part Name(EN)	Qty.	Recommend store spare parts
1	12223000010753	Side panel assembly	1	
2	12223000002193	Side panel assembly	1	
3	11201708000008	Wiring Terminal	1	
4	12223000002125	Air duct assy'	1	YES
5	17223000005676	E-part box assembly	1	
5.1	17123000000700	Electronic control(display) box subassembly of indoor unit	1	
5.2	12223000002167	Electric installation board	1	
6	11203103000141	Linear Transformer	1	YES
7	12223000002231	Side panel assembly	1	
8	12100304000011	Clamp	1	
9	12223000002356	Base assembly	1	
10	12223000001943	Drainage pan supporting board	2	
11	12223000010761	Supporter assembly	1	
12	12223000010756	Drainage pan clamp	2	
13	12223000001213	Drainage pan	1	YES
14	12223000010789	Cover plate ass'y	1	
15	12223000010766	Drainage pan supporter III	2	
16	12123000000099	Drain pan ass'y	1	YES
17	12223000000028	Fixing board of water collector	2	
18	15500402000023	seal plug	2	
19	12223000000417	Supporting bar	1	
20	12223000002002	Cover board	1	
21	11301230000002	Screw	2	
22	15823000004961	Evaporator assembly	1	YES
22.1	15223000000167	Output pipe assembly	1	
22.2	15423000004539	Evaporator input pipe assembly	1	
22.3	15823000004401	Evaporator	2	
22.4	15500210000968	Throttle	1	YES
22.5	15500220000030	Valve core	1	YES
22.6	12100901000010	Sealing ring	1	YES
22.7	15500302000014	Flange joint	1	YES
22.8	15500402000107	Nut	1	
23	11301002000673	Hexagon head bolt and plain washer	3	
24	12223000001932	Supporter subassembly of fan motor	3	
25	12223000001992	Supporter of fan motor	1	
26	11002015007642	Brushless DC Motor	1	YES
27	11301705000106	Hexagon head bolt	1	
28	12200101000018	Fan ass'y	1	YES
29	15500302000006	Attachment-flange connection pipe	1	YES

Due to ongoing product improvements, specifications and dimensions are subject to change and correction without notice or incurring obligations. Determining the application and suitability for use of any product is the responsibility of the installer. Additionally, the installer is responsible for verifying dimensional data on the actual product prior to beginning any installation preparations.

Incentive and rebate programs have precise requirements as to product performance and certification. All products meet applicable regulations in effect on date of manufacture; however, certifications are not necessarily granted for the life of a product. Therefore, it is the responsibility of the applicant to determine whether a specific model qualifies for these incentive/rebate programs.

Comfort-Cire®  **Century**®